

4-BLOCK

4" Close-coupled electric submersible pumps



Clean water



Civil use



Domestic use



Agricultural use



※ **Ready-to-install stainless steel submersible pump equipped with an integrated capacitor and thermal protector.**

※ **Patented hydraulics featuring fully independent, floating impellers, ensuring minimal impact from sand on pump performance.**

※ **These hydraulics have a minimum efficiency index (MEI) that far exceeds ErP requirements.**

※ **Outstanding performance .**

※ **Comes with a 20 m power cable.**

PERFORMANCE RANGE

- Flow rate up to **225 l/min** (13.5 m³/h)
- Head up to **124 m**

INSTALLATION AND USE

Designed to draw water from clean wells, even in the presence of sand (up to **200 g/m³**).

With their high efficiency, reliability, and ease of installation, they are highly recommended for domestic, commercial, and agricultural applications. They are ideal for automatic water distribution alongside pressure tanks, irrigation systems, and more.

APPLICATION LIMITS

- Liquid temperature up to **+35 °C**
- Maximum sand content **200 g/m³**
- Capable of operating at depths of up to **100 metres** below water level (with an appropriately sized power cable)
- Vertical and horizontal operation
- Starts per hour: **20** at regular intervals

AVAILABLE UPON REQUEST

- ※ **30 metres** long power cable
- ※ Different voltage or frequency

PERFORMANCE RANGE

60 Hz

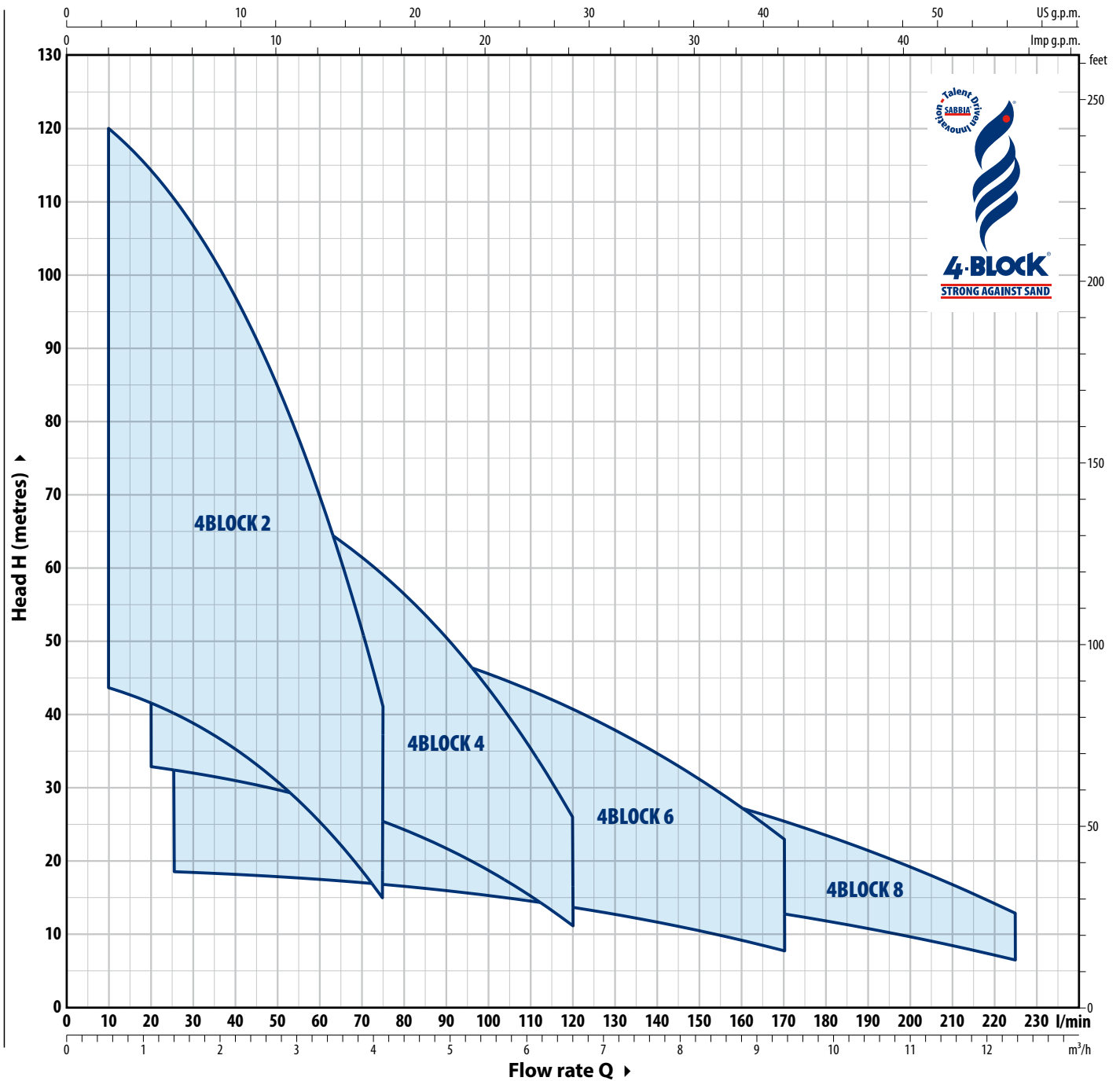

PATENTS - TRADE MARKS - MODELS

- European Patents No. EP3123031, EP2419642
- Patent No. 102021000030575
- **4-BLOCK®** is a registered trademark No. 018702380



4-BLOCK

4" Close-coupled electric submersible pumps

PERFORMANCE RANGE

60 Hz

4-BLOCK 2

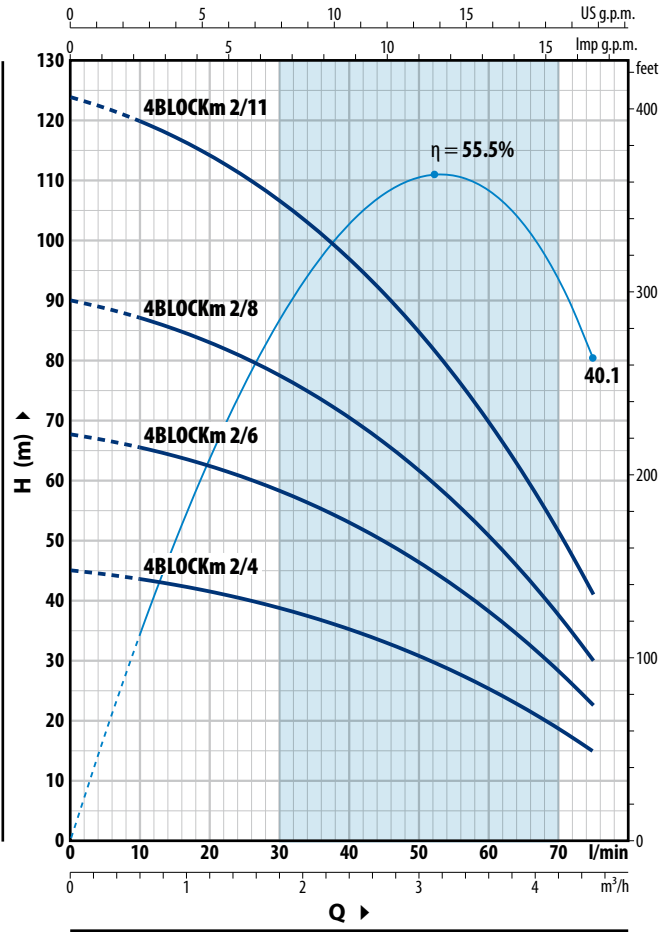

4-BLOCK 4

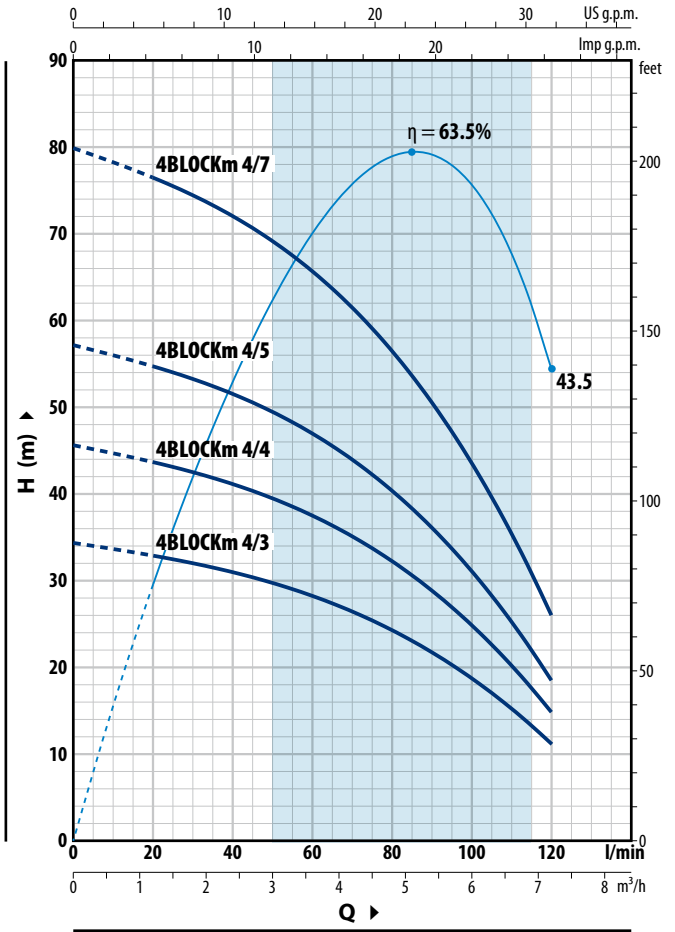

4-BLOCK 2

TYPE	POWER (P ₂)		Q	Flow rate													
	kW	HP		m ³ /h	0	0.6	1.2	1.8	2.4	3	3.6	4.5					
Single-phase				0	10	20	30	40	50	60	75						
4-BLOCKm 2/4	0.37	0.50	H metres	45	43.5	41.5	38.5	35	31	25.5	15						
4-BLOCKm 2/6	0.55	0.75		67.5	65.5	62	58	53	46	38	22.5						
4-BLOCKm 2/8	0.75	1		90	87	83	77	70	61.5	50.5	30						
4-BLOCKm 2/11	1.1	1.5		124	120	114	107	97	85	69.5	41						

4-BLOCK 4

TYPE	POWER (P ₂)		Q	Flow rate												
	kW	HP		m ³ /h	0	1.2	1.8	2.4	3	3.6	4.2	4.8	5.4	6	7.2	
Single-phase				0	20	30	40	50	60	70	80	90	100	120		
4-BLOCKm 4/3	0.37	0.50	H metres	34.5	33	32	31	29.5	28	26.4	24.2	21.7	18.7	11		
4-BLOCKm 4/4	0.55	0.75		45.5	43.5	42.5	41	39.5	37.5	35	32.5	29	24.9	15		
4-BLOCKm 4/5	0.75	1		57	54.5	53	51.5	49.5	47	44	40.5	36	31	18.5		
4-BLOCKm 4/7	1.1	1.5		80	77	75	72	69	65.5	61.5	56.5	50.5	43.5	26		

Q = Flow rate H = Total manometric head

Performance curves comply with EN ISO 9906 Grade 3B tolerance limits.

PERFORMANCE RANGE

60 Hz

4-BLOCK 6

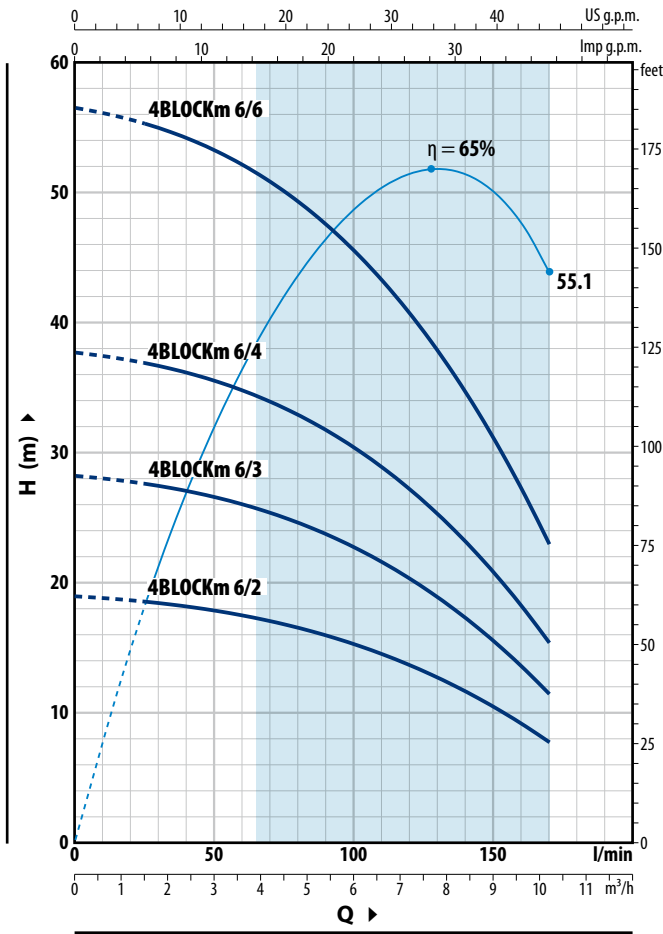

4-BLOCK 8

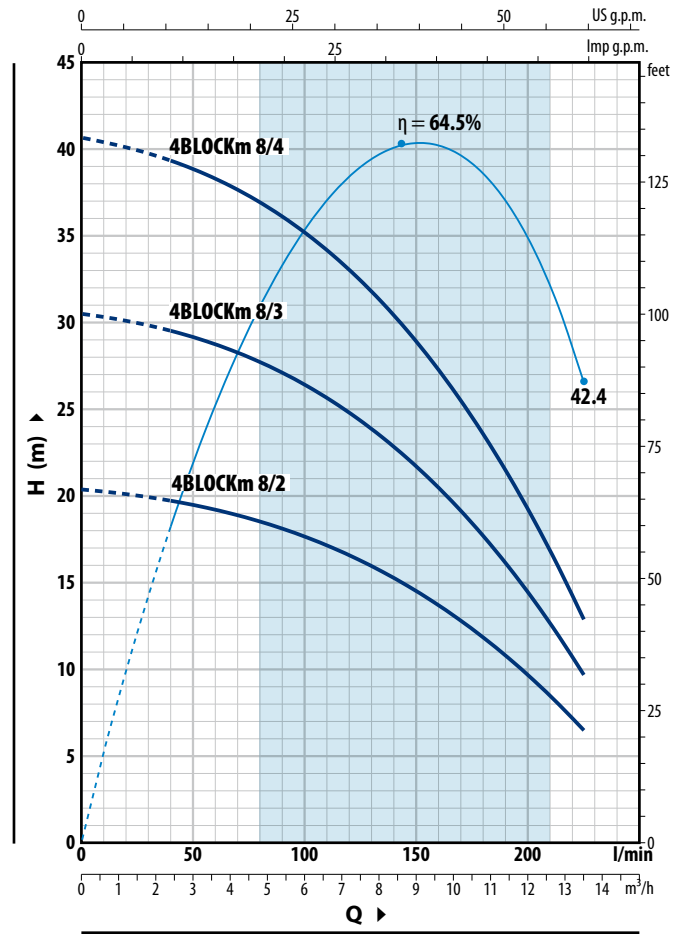

4-BLOCK 6

TYPE	POWER (P ₂)		Q	Flow Rate (m³/h)													
	kW	HP		0	1.5	3	4.5	6	7.5	9	10.2						
Single-phase			l/min	0	25	50	75	100	125	150	170						
4-BLOCKm 6/2	0.37	0.50	H metres	19	18.5	17.8	16.8	15.2	13.2	10.4	7.5						
4-BLOCKm 6/3	0.55	0.75		28.5	28	26.7	25.2	22.9	19.7	15.6	11.5						
4-BLOCKm 6/4	0.75	1		38	37	35.5	33.5	30.5	26.3	20.8	15.5						
4-BLOCKm 6/6	1.1	1.5		57	55.5	53.5	50.5	45.5	39.5	31.5	23						

4-BLOCK 8

TYPE	POWER (P ₂)		Q	Flow Rate (m³/h)													
	kW	HP		0	2.4	3.6	4.5	6	7.5	9	10.5	12	13.5				
Single-phase			l/min	0	40	60	75	100	125	150	175	200	225				
4-BLOCKm 8/2	0.55	0.75	H metres	20.5	19.5	19.2	18.7	17.6	16.2	14.5	12.3	9.6	6.5				
4-BLOCKm 8/3	0.75	1		30.5	29.5	29	28	26.4	24.3	21.7	18.4	14.4	9.5				
4-BLOCKm 8/4	1.1	1.5		40.5	39.5	38.5	37.5	35	32.5	29	24.6	19.2	13				

Q = Flow rate H = Total manometric head

Performance curves comply with EN ISO 9906 Grade 3B tolerance limits.

MATERIALS AND COMPONENTS

1 Delivery port and pump jacket	Stainless steel AISI 304 with thread according to ISO 228/1	
2 Pump bearing	EPDM	
3 Impellers	Delrin®	
4 Diffusers	Noryl™	
5 Stadium boxes	Stainless steel AISI 304	
6 Pump shaft	Stainless steel AISI 304	
7 Cable sheath	Stainless steel AISI 304	
8 Filter	Stainless steel AISI 304	
9 Coupling motor bracket	Technopolymer and brass	
10 Motor shaft	Stainless steel AISI 431	
11 Motor sleeve	Stainless steel AISI 304	
12 Mechanical seal	Seal	Materials
	ST4-16	Ceramic / Graphite / NBR
13 Capacitor		
14 Electric motor	<ul style="list-style-type: none"> - Specially dimensioned submersible rewindable oil filled motor, suitable for continuous service (non-toxic food-safe oil). - Single-phase 220 V - 60 Hz - Built-in motor capacitor - Thermal motor protection incorporated in the winding - Continuous running duty S1 - Insulation: Class F - Protection rating: IP X8 	
15 Compensating diaphragm		
16 Power cord	<p>☛ DRINCABLE® HRC certified for use with drinking water meant for human consumption by the ACS according to XP P 41-250, approval no. 18 MAT NY 156</p> <p>Standard length 20 metres</p>	

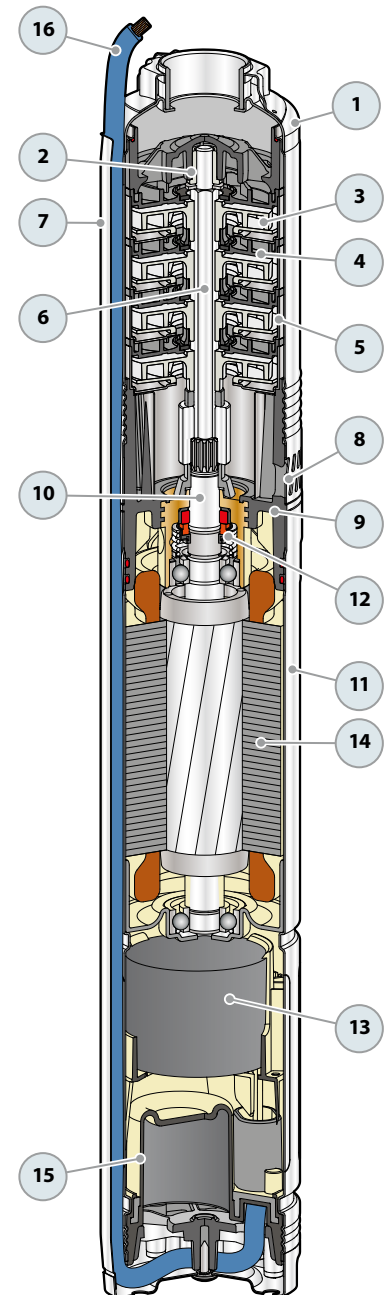

DIMENSIONS AND WEIGHT

TYPE	PORT DN	DIMENSIONS mm			kg
		NO. STAGES	Ø	h	
Single-phase					1~
4-BLOCKm 2/7	1 1/4"	7	100	617	11.4
4-BLOCKm 2/10		10		677	12.3
4-BLOCKm 2/13		13		757	13.9
4-BLOCKm 2/18		18		907	17.0
4-BLOCKm 4/5		5		602	11.5
4-BLOCKm 4/7		7		652	12.1
4-BLOCKm 4/9		9		722	13.3
4-BLOCKm 4/13		13		872	16.4
4-BLOCKm 6/3		3		572	11.4
4-BLOCKm 6/5		5		635	12.0
4-BLOCKm 6/7		7		718	13.2
4-BLOCKm 6/10		10		862	16.4
4-BLOCKm 8/3		3		572	12.0
4-BLOCKm 8/5		5		655	12.6
4-BLOCKm 8/8		8		799	15.8

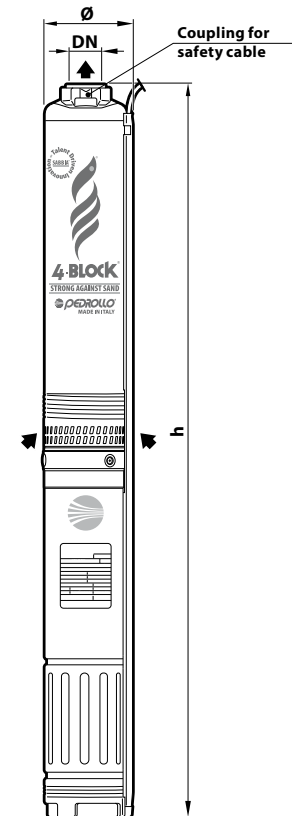

ABSORPTION

TYPE	VOLTAGE
Single-phase	220 V
4-BLOCKm - 0.37 kW	3.5 A
4-BLOCKm - 0.55 kW	4.4 A
4-BLOCKm - 0.75 kW	6.1 A
4-BLOCKm - 1.1 kW	8.0 A

PALLET CAPACITY

TYPE	NO. OF PUMPS
Single-phase	
4-BLOCKm 2	55
4-BLOCKm 4	55
4-BLOCKm 6	55
4-BLOCKm 8	55

Typical installation

